

Thakur Educational Trust's (Regd.)
THAKUR VIDYA MANDIR HIGH SCHOOL & JUNIOR COLLEGE
I Term Paper 2016-17
Subject : English

Name : _____ Std: I Div : _____ Roll No. _____

Marks

: 60

DATE - 27.09.2016

Time : 2 hrs 45

mins

Q. I. A] Fill in the blanks by choosing the correct words from the bracket:-

(5)

(garden, flowers, doctor, morning, scarf)

- 1) She left her _____ in the bus.
- 2) It was Sunday _____.
- 3) Rohan and Sania took the doggie to a _____.
- 4) There were many _____ in the shop.
- 5) It is fun to work in the _____.

B] Write the opposite for:

(3)

- 1) come x _____ 2) in x _____ 3) take x _____

C] Give rhyming words for:

(3)

- 1) can = _____ 2) soon = _____ 3) ball = _____

Q II A] Find the smaller word in:

(5)

- 1) ball - _____ 2) garden - _____ 3) also - _____
4) hair- _____ 5) pencil- _____

B] Complete the given word by filling in the missing letters:

(4)

- 1) n _ _ m _ _ 2) d o _ _ i e
3) i _ _ a g _ _ 4) w _ _ o _ _ g

C] Circle the correct word:

(5)

- 1) Munnu wanted to buy a colourful (ball/balloon).
- 2) Raju put on (clean/dirty) clothes.
- 3) Munnu went to the park with her (father/mother).
- 4) Raju was (playing/lying) in his bed.
- 5) Munnu's meals became quite (colourful/colourless).

Q III A] Make sentences:

(3)

1) help - _____

2) water - _____

3) money - _____

(1)

B] Who said to whom ?

(2)

1) "We can pick up dry leaves."

Ans: _____

2) "Colourful meals are good meals."

Ans: _____

C] Answer the following:

(10)

1) How is the pink rose ?

Ans: _____

2) What did Munnu like to eat ?

Ans: _____

3) Where did Rohan and Sania take the doggie?

Ans: _____

4) What kind of friends did Raju like ?

Ans: _____

5) Where did she leave the money ?

Ans: _____

Grammar

QI Do as directed:

1) Write the words in capital and small letters:

(1)

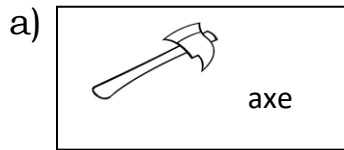

(2)

2. Fill in the blanks:

(1)

a) _____ is the day before Friday.

3. a) Write the missing vowels :

(1)

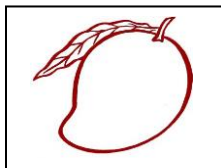

m _ n g _

b) Circle the consonants in the given word :

(1)

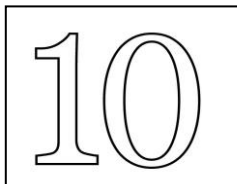

t e n

c] Use 'a' or 'an' to complete the sentences :

(1)

i) This is _____ umbrella.

ii) Heena is riding _____ bicycle.

4. Write the correct name under each picture:

(2)

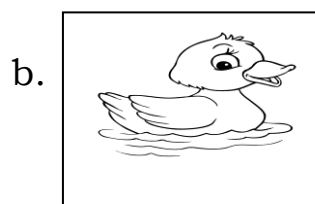
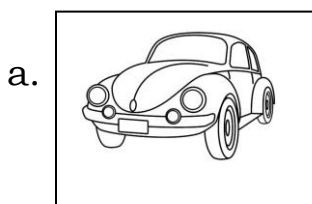

_____ [car/ lamp]

_____ [eagle/ duck]

5. Look at the picture and choose the name of the helper from

(1)

the bracket:



_____ [teacher / baker]

6. Underline the naming word in the sentences:

(1)

- a. Reema won the race.
- b. Mohan was not well.

7. Circle the correct word given under the picture:

(1)

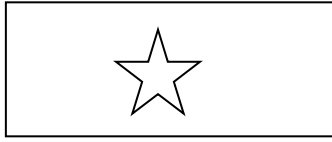

[star / stars]

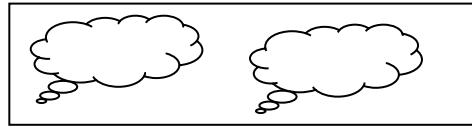

[cloud / clouds]

(3)

8. Match the pairs correctly:

(2)

a)

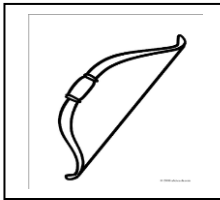

b)

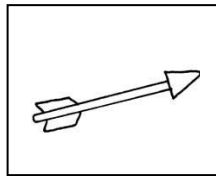
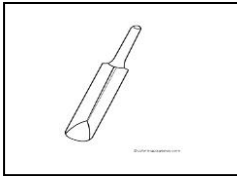

9. Write the young one of :

(1)

hen - _____ [chick/pup] .

10. Choose the correct word from the bracket and fill in the

(1)

correct gender :

a) _____ and cow [hen / bull]

11. Fill in the blank with ' He ' ' She ' or ' It ' :

(1)

a) _____ is a balloon.

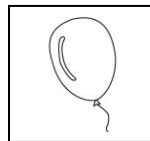

QII] Write five sentences on the topic: 'Trees'

(5)

1. _____

2.

3.

4.

5.

All the best

THAKUR VIDYA MANDIR HIGH SCHOOL & JUNIOR COLLEGE

I Term Re-examination Paper 2016-2017

Subject : Mathematics

Name : _____ **Std: I Div :** _____ **Roll No.** _____

Date : 29/09/2016

Marks : 60

Duration : 2 hrs. 30 min.

Q. I.A] Write in numerals : (4)

1) twenty two – _____

2) sixteen – _____

3) forty one – _____

4) twelve – _____

B] Write in words : (4)

a) 10 - _____

b) 18 – _____

c) 21 - _____

b) 50 – _____

C] Write the given numbers in serial order : (2)

4, 2, 3, 1

--	--	--	--

Q.II. 1] Draw one line for every object in the picture : (2)

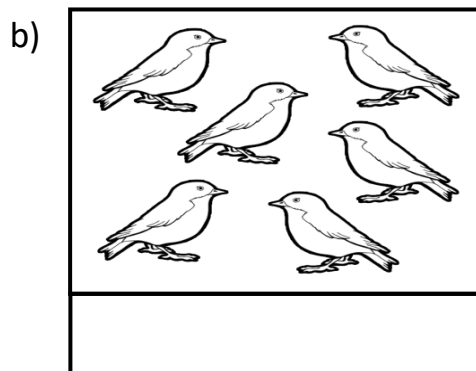
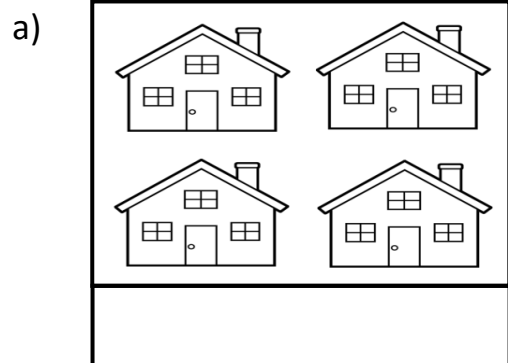

2] Count the objects and circle the correct number : (2)

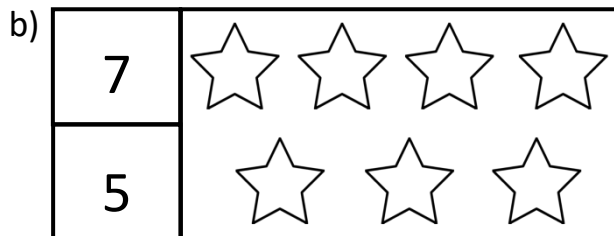
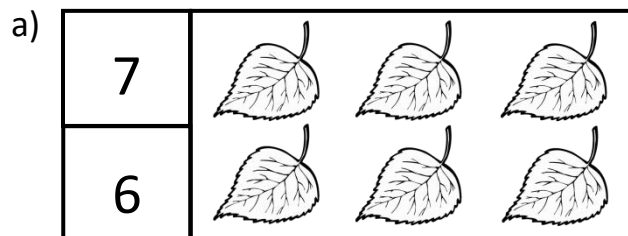

3] Draw as many dots/lines as the given number : (2)

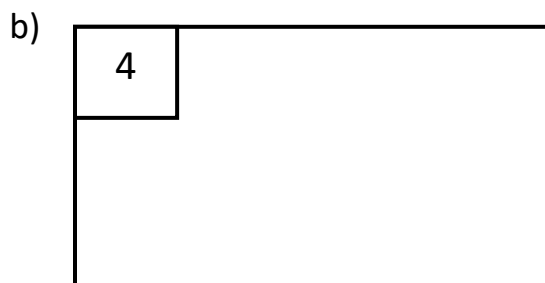
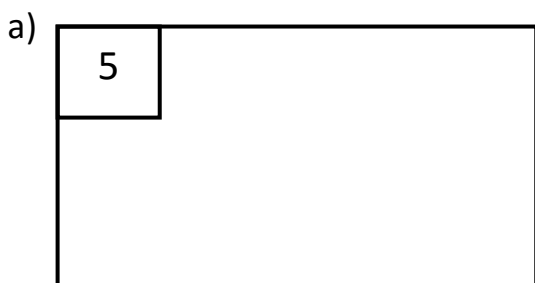

: 2 :

Q.II. 4] Draw more objects than the given ones:

(1)

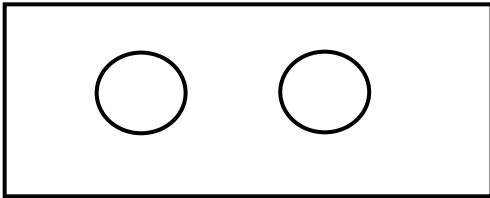

5] Draw less objects than the given ones :

(1)

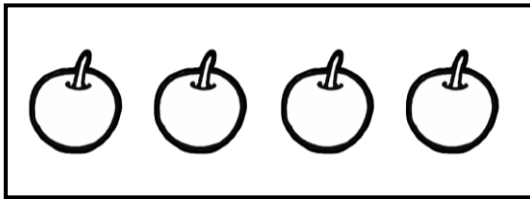

6] Colour as many objects as the given number :

(2)

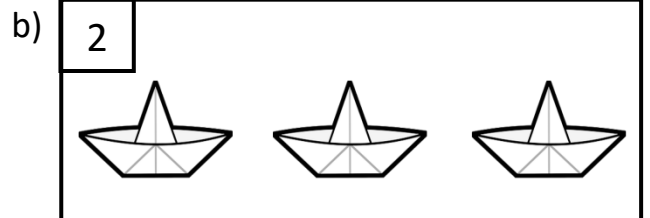
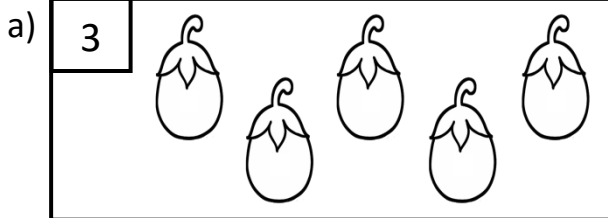

Q.III.A. 1] Count the objects in each group and write the number in the box. (3)

Write the bigger number in the circle :

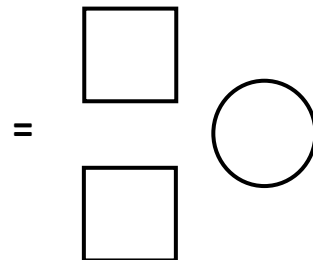
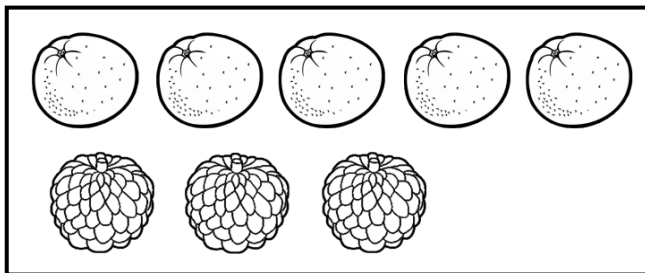

2. Count the objects in each group and write the number in the box. (3)

Write the smaller number in the circle :

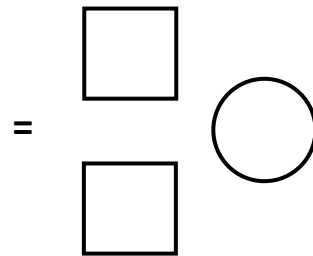
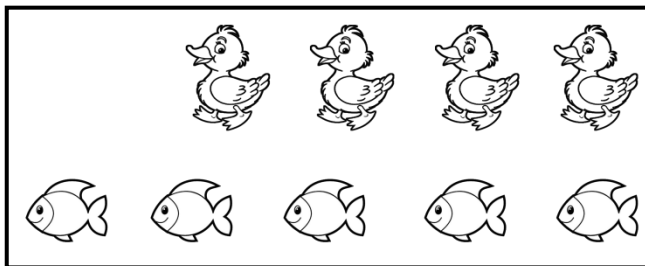

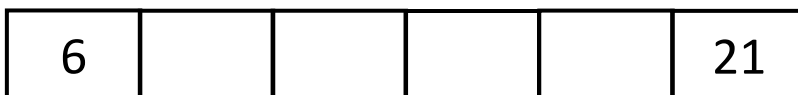

Q.III. B] Write the numbers in reverse order :

(4)

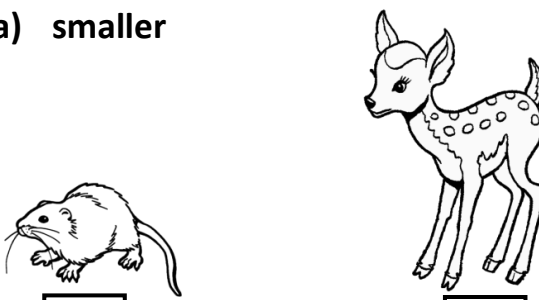
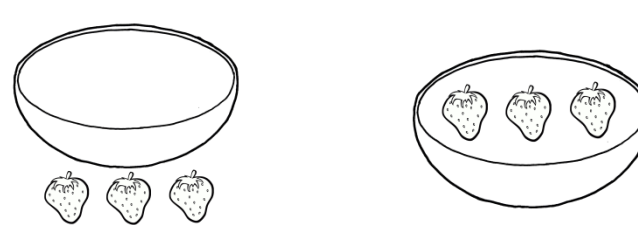
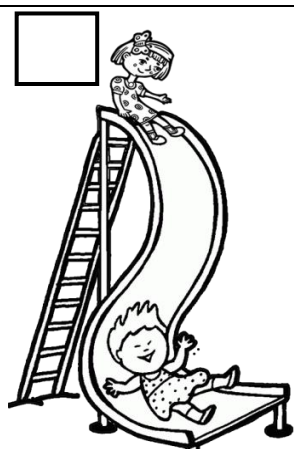

Q.IV. 1] Tick the one that is :

(4)

<p>a) smaller</p>  <p><input type="checkbox"/> <input type="checkbox"/></p>	<p>b) in the basket</p>  <p><input type="checkbox"/> <input type="checkbox"/></p>
<p>c) up</p>  <p><input type="checkbox"/> <input type="checkbox"/></p>	<p>d) Far from the tree</p>  <p><input type="checkbox"/> <input type="checkbox"/></p>

2) Make one to one pairs. Put a tick for the equal objects. Put a cross for the unequal objects : (2)

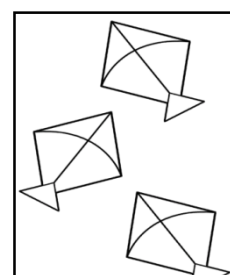
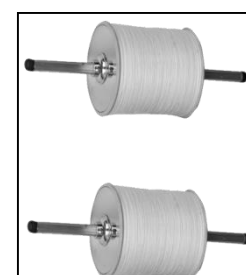

a)

	 <p><input type="checkbox"/></p>
---	--

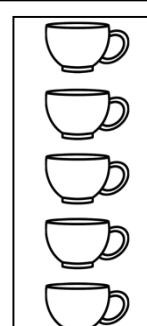
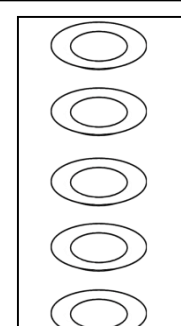
b)

	 <p><input type="checkbox"/></p>
---	--

3) Match the objects having similar shapes. (4)

	
---	--

: 4 :

Q.V. 1] Write the number before and after the given number.

(6)

	8	
	2	
	5	

2] Fill in the boxes :

(4)

a) $2 \times 2 =$ b) $1 \times 7 =$ c) $1 \times 9 =$ d) $2 \times 5 =$

Q.VI. A] Count and write the correct number in each box and complete the addition.

(6)

1)

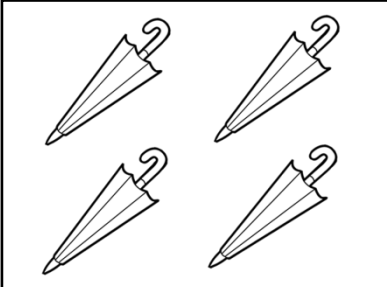
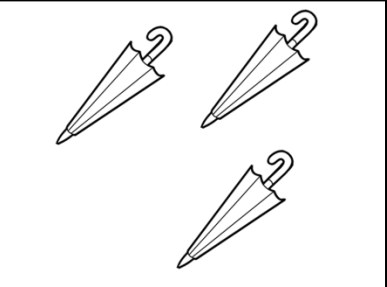
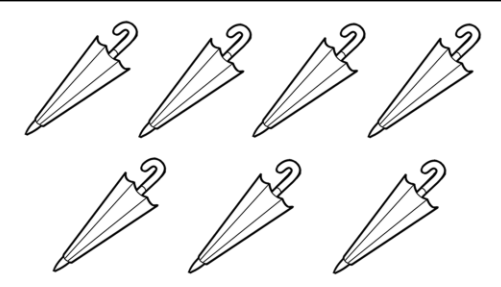
				
<input type="text"/>	+	<input type="text"/>	=	<input type="text"/>

2)

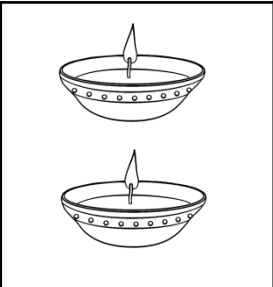
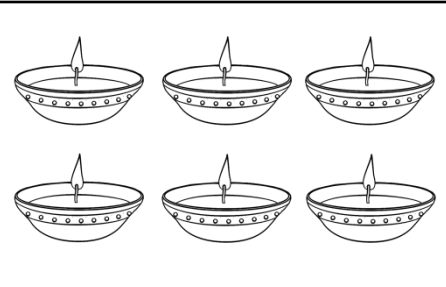
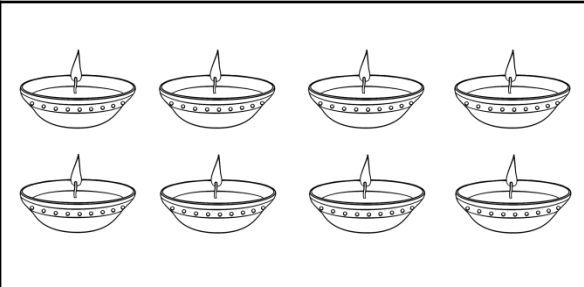
				
<input type="text"/>	+	<input type="text"/>	=	<input type="text"/>

B] Add :

(4)

a) $5 + 2 =$ b) $3 + 3 =$

c) $4 + 1 =$ d) $3 + 2 =$

*** All the Best ***